



Philips
Professional LED LCD TV

22" EasySuite

LED DVB-T/C MPEG 2/4

22HFL3233D



A I R  W A V E

Impress your guests, most efficiently

Philips Hospitality LED LCD TV

With this modern and energy efficient Hospitality LED LCD TV, you will enjoy all the benefits of digital television. Your guests will enjoy a warm welcome and great viewing experience with this professional hotel TV.

Advanced hotel features and future proof

- Brilliant LED images with low power consumption
- Full Hotel, Healthcare and Prison Modes
- MyChoice compatibility for recurring revenues
- Integrated Connectivity Panel
- Installation menu locking

Differentiating guest experience

- ThemeTV Lite for easy channel navigation
- Hotel Scenea for a tailored info and start-up channel
- Additional headphone connection for personal listening

Sustainable and safe

- Low power consumption
- Green Button allows guest to save even more energy
- Eco-friendly design & flame retardant housing



PHILIPS

sense and simplicity

www.airwave.tv

Highlights

LED



LED lighting technology is the most advanced available. In this TV it combines an eye-catching minimalistic design with stunning image quality and on top the lowest power consumption in its category. An other environmental benefit is that LED lighting technology does not contain hazardous materials. With LED backlight you can enjoy low power consumption, high brightness, incredible contrast and sharpness and vibrant colors.

MyChoice compatible

MyChoice offers a simple and low-cost way to offer your guests premium TV channels. At the

same time it delivers an additional revenue stream which allows you to recover your initial TV investment.

ThemeTV Lite

ThemeTV Lite offers an easy user interface that gives your guests the opportunity to navigate in the guest menu to find their own country channels, news and hotel information easily without the need of an interactive entertainment system.

Hotel Scenea

Hotel Scenea allows you to select and store image on the TV which can be displayed as start-up or info channel.

Integrated Connectivity Panel

The Integrated Connectivity Panel allows your guests to seamlessly connect their personal devices to your TV without the need of any external Connectivity Panel.

Green Button

With the Green Button guests have the possibility to save even more energy on the TV by opting for a higher backlight dimming or by switching off the screen when listening to radio. Another way to reduce a hotel's operating cost while involving guests directly.

Eco-friendly design

Sustainability is integral to the way Philips does business. Philips TVs are designed and produced according to our EcoDesign principles aimed at minimizing overall environmental impact, through lower power consumption, removal of hazardous substances, lower weight, more efficient packaging and better recyclability. Philips TVs also have a special housing of flame retardant material. Independent tests carried out by emergency fire services have shown that whereas TVs can sometimes intensify fires caused by external sources, Philips TVs will not contribute to the fire.



Energy Class B

EU Energy Label

For many years Philips has pro-actively been working on the reduction of both on-mode and standby power consumption of its televisions and as a result most Philips televisions has achieve green EU energy labels in 2010. The greener the label, the lower the on-mode power consumption and the lower your energy bill and friendlier to the environment



Specifications

Picture/Display

- Diagonal screen size: 22 inch / 56 cm
- Aspect ratio: Widescreen
- Display screen type: LCD WXGA+ Active Matrix TFT
- Panel resolution: 1366 x 768p
- Brightness: 300 cd/m²
- Response time (typical): 6 ms
- Picture enhancement: 3/2 - 2/2 motion pull down, 3D Combfiter, Color Enhancement, Color Transient Improvement, Digital Crystal Clear, Digital Noise Reduction, Luminance Transient Improver, Sharpness Adjustment, 3D MA deinterlacing, Automatic skin tone correction, Dynamic contrast enhancement, 1080p 24/25/30Hz processing, 1080p 50/60Hz processing, Active Control
- Dynamic screen contrast: 150,000:1
- Screen enhancement: Anti-Reflection coated screen
- Viewing angle: 178° (H) / 178° (V)
- Color cabinet: Whiskey tint deco front with high gloss black cabinet

Supported Display Resolution

Video formats

Resolution	Refresh rate
480i	60Hz
480p	60Hz
576i	50Hz
576p	50Hz
1080i	50, 60Hz
720p	50, 60Hz
1080p	24, 50, 60Hz
1080p	24, 25, 30, 50, 60Hz

Computer formats

Resolution	Refresh rate
640 x 480	60Hz
800 x 600	60Hz
1024 x 768	60Hz
1280 x 1024	60Hz
1280 x 720	60Hz
1280 x 768	60Hz
1360 x 768	60Hz

Tuner/Reception/Transmission

- Aerial Input: 75 ohm coaxial (IEC75)
- Number of Preset Channels: 999
- Tuner bands: Hyperband, S-Channel, UHF, VHF

- TV system: PAL I, PAL B/G, SECAM B/G, SECAM L/L', DVB COFDM 2K/8K, PAL D/K, SECAM D/K
- Video Playback: PAL, SECAM, NTSC
- Digital TV: DVB-T MPEG4, DVB-C MPEG4*

Sound

- Output power (RMS): 2 x 3W
- Sound System: Nicam Stereo
- Sound Enhancement: Auto Volume Leveller, Incredible Surround, Smart Sound, Treble and Bass Control

Loudspeakers

- Built-in speakers: 2

Connectivity

- Number of Scarts: 1
- Number of HDMI connections: 2
- Ext 1 Scart: Audio L/R, RGB, CVBS in
- Front / Side connections: Audio L/R in, CVBS in, Headphone out, USB 2.0, HDMI v1.3
- HDMI 1: HDMI v1.3
- EasyLink (HDMI-CEC): One touch play, System standby
- Other connections: PC-in VGA + Audio L/R in, Antenna IEC75, Common Interface Plus (CI+), S/PDIF out (coaxial)
- Ext 2: YPbPr in

Convenience

- Ease of Installation: Plug & Play, Advanced Hotel Mode, Automatic Tuning System (ATS), Fine Tuning, PLL Digital Tuning, Automatic Channel Install(ACI), Auto Program Naming, Autostore, Cloning of TV settings via USB, Installation menu locking, Security menu access, Keyboard lock-out, Cloning of TV settings via RF
- Ease of Use: Auto Volume Leveller (AVL), On Screen Display, Program List, Side Control, Graphical User Interface, 1 channel list analog/digital
- Comfort: Hotel Guest features, Welcome message, Switch on channel, Volume limitation, Sleep timer
- Interactive hotel features: Block automatic channel update, Block over-the-air SW download, MyChoice, ThemeTV Lite
- Prison mode: Txt, MHEG, USB, EPG, Sub block
- Clock: Sleep Timer

- Teletext: 1000 page Smart Text
- Electronic Program Guide: 8 day Electronic Program Guide, Now + Next EPG
- Screen Format Adjustments: 4:3, Movie expand 14:9, Movie expand 16:9, Widescreen, Subtitle Zoom, Super Zoom, Auto Format
- Remote control type: 22AV1104C (RC6)
- Remote Control: low battery detection, battery anti-theft protection
- Firmware upgradeable: Firmware upgradeable via USB, Firmware upgradeable via RF
- Other convenience: Kensington lock

Healthcare

- Control: Multi remote control
- Convenience: Headphone out, Independent main speaker mute
- Safety: Double isolation Class II

Multimedia Applications

- Multimedia connections: USB
- Playback Formats: MP3, JPEG Still pictures
- Video Playback Formats: H264/MPEG-4 AVC, MPEG-1, MPEG-2, MPEG-4

Power

- Mains power: 220-240V, 50/60Hz
- Power consumption (typical): 29 W
- Ambient temperature: 5 °C to 35 °C
- Annual energy consumption: 41 kW h
- Presence of lead: Yes*

Green Specifications

- Safety: Flame retardant housing
- Low Power Standby
- SmartPower Eco

Dimensions

- Set dimensions (W x H x D): 526 x 343 x 49.4 mm
- Set dimensions with stand (W x H x D): 526 x 369 x 149 mm
- Box dimensions (W x H x D): 580 x 426 x 133 mm
- Product weight: 4 kg
- Product weight (+stand): 4.2 kg
- VESA wall mount compatible: 75 x 75 mm

Accessories

- Included accessories: Remote Control, Batteries for remote control, Power cord, Table top stand, Warranty Leaflet
- Optional accessories: Wallmount (tilt) 22AV3100/10, Set up remote 22AV8573/00

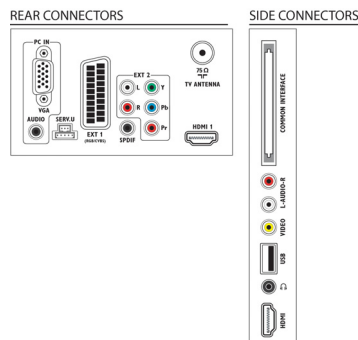

Issue date 2011-07-25

Version: 3.0.4

12 NC: 8670 000 75935
EAN: 87 12581 60236 9

© 2011 Koninklijke Philips Electronics N.V.
All Rights reserved.

Specifications are subject to change without notice.
Trademarks are the property of Koninklijke Philips Electronics N.V. or their respective owners.

www.philips.com