

Preliminary

A I R  W A V E



Philips  
Professional LED TV

22" EasySuite

LED DVB-T/C MPEG 2/4

22HFL3007D

## Great value in a modern design

with thin and powersaving LED technology

With this thin and energy efficient Hospitality LED LCD TV, you will enjoy all the benefits of digital television. Allow your guests to buy premium content and use the latest remote technology for effortless installation.

### Advanced hotel features and future proof

- Full Hotel, Healthcare and Prison Modes
- MyChoice compatibility for recurring revenues
- Integrated Connectivity Panel
- SmartInstall for easy remote installation and maintenance
- Brilliant LED images with incredible contrast

### Differentiating guest experience

- ThemeTV Lite for easy channel navigation
- Additional headphone connection for personal listening
- SmartInfo for a branded, interactive experience even offline

### Sustainable and safe

- Low power consumption
- Green Button allows guest to save even more energy
- Eco-friendly design & flame retardant housing

**PHILIPS**

sense and simplicity

[www.airwave.tv](http://www.airwave.tv)

# Highlights

### MyChoice compatible

MyChoice offers a simple and low-cost way to offer your guests premium TV channels. At the same time it delivers an additional revenue stream which allows you to recover your initial TV investment.

### ThemeTV Lite

ThemeTV Lite offers an easy user interface that gives your guests the opportunity to navigate in the guest menu to find their own country channels, news and hotel information easily without the need of an interactive entertainment system.

### Integrated Connectivity Panel

The Integrated Connectivity Panel allows your guests to seamlessly connect their personal devices to your TV without the need of any external Connectivity Panel.

### Green Button

With the Green Button guests have the possibility to save even more energy on the TV by opting for a higher backlight dimming or by switching off the screen when listening to radio. Another way to reduce a hotel's operating cost while involving guests directly.

### Eco-friendly design

Sustainability is integral to the way Philips does business. Philips TVs are designed and produced according to our EcoDesign principles aimed at minimizing overall environmental impact, through lower power consumption, removal of hazardous substances, lower weight, more efficient packaging and better recyclability. Philips TVs also have a special housing of flame retardant material. Independent tests carried out by emergency fire services have shown that whereas TVs can sometimes intensify fires caused by external sources, Philips TVs will not contribute to the fire.

### SmartInfo

SmartInfo allows you to provide hotel or city information to your guests through SmartUI. Your guests have access to this interactive hotel webpage even when the TV is not connected to your intranet or internet. You can change the information regularly and easily to keep your guests up to date with all the latest developments in your hotel.

### SmartInstall

SmartInstall makes installation and maintenance of your TVs effortless. With a

simple to use web tool, you can now remotely configure and install your TVs without visiting any rooms! This saves you time and makes sure your guests are not disturbed. Whether it is updating the hotel info pages or installing new channels, SmartInstall can handle all.

### Full HD LED TV



The most advanced LED lighting technology in this Full HD LED TV combines an eye-catching minimalistic design with stunning image quality as well as the lowest power consumption in its category. On top of that, LED lighting technology does not contain any hazardous materials. Thus, with LED backlight you can enjoy low power consumption, high brightness, incredible contrast, sharpness and vibrant colors.



## Specifications

### Picture/Display

- Diagonal screen size: 22 inch / 56 cm
- Aspect ratio: 16:9
- Panel resolution: 1920x1080p
- Brightness: 250 cd/m<sup>2</sup>
- Picture enhancement: Digital Crystal Clear, 100 Hz Perfect Motion Rate
- Dynamic screen contrast: 100.000:1
- Viewing angle: 170° (H) / 160° (V)
- Color cabinet: high gloss black cabinet
- Display: LED Full HD

### Supported Display Resolution

- Computer inputs: up to 1920x1080 @ 60Hz
- Video inputs: 24, 25, 30, 50, 60 Hz, up to 1920x1080p

### Tuner/Reception/Transmission

- Aerial Input: 75 ohm coaxial (IEC75)
- Video Playback: PAL, SECAM, NTSC
- Digital TV: DVB-T MPEG4, DVB-C MPEG4\*, DVB-C MPEG2\*, DVB-T MPEG2\*

### Sound

- Output power (RMS): 6W (2 x 3W)
- Sound Enhancement: Auto Volume Leveller, Incredible Surround, Treble and Bass Control, Clear Sound

### Loudspeakers

- Built-in speakers: 2

### Connectivity

- Number of HDMI connections: 3
- EasyLink (HDMI-CEC): One touch play, System standby
- Other connections: PC-in VGA + Audio L/R in, Antenna IEC75, Common Interface Plus (CI+), Digital audio out (coaxial), Headphone out
- Number of AV connections: 1
- Number of component in (YPbPr): 1
- Number of scarts (RGB/CVBS): 1
- Number of USBs: 1

### Convenience

- Ease of Installation: Plug & Play, Advanced Hotel Mode, Automatic Tuning System (ATS), Fine Tuning, PLL Digital Tuning, Automatic Channel Install(ACI), Auto Program Naming, Autostore,

- Cloning of TV settings via USB, Installation menu locking, Security menu access, Keyboard lock-out, Cloning of TV settings via RF
- Ease of Use: Auto Volume Leveller (AVL), On Screen Display, Program List, Side Control, Graphical User Interface, 1 channel list analog/digital
- Comfort: Hotel Guest features, Welcome message, Switch on channel, Volume limitation, Sleep timer
- Interactive hotel features: Block automatic channel update, MyChoice, ThemeTV Lite
- Prison mode: Txt, MHEG, USB, EPG, Sub block
- Teletext: 1000 page Smart Text
- Electronic Program Guide: 8 day Electronic Program Guide, Now + Next EPG
- Screen Format Adjustments: 4:3, Movie expand 14:9, Movie expand 16:9, Widescreen, Subtitle Zoom, Super Zoom, Auto Format
- Remote control type: 22AV1108A (RC6)
- Remote Control: low battery detection, battery anti-theft protection
- Firmware upgradeable: Firmware upgradeable via USB, Firmware upgradeable via RF
- Other convenience: Kensington lock

### Healthcare

- Control: Multi remote control
- Convenience: Headphone out, Independent main speaker mute
- Safety: Double isolation Class II

### Multimedia Applications

- Multimedia connections: USB
- Video Playback Formats: H264/MPEG-4 AVC, MPEG-1, MPEG-2, MPEG-4
- Music Playback Formats: AAC, MP3
- Picture Playback Formats: JPEG

### Power

- Mains power: 220-240V, 50/60Hz
- Ambient temperature: 5 °C to 35 °C
- Annual energy consumption: tbc kWh
- Standby power consumption: <0.3W

### Green Specifications

- Safety: Flame retardant housing
- Low Power Standby
- SmartPower Eco

### Dimensions

- Set dimensions (W x H x D): 519.8 x 340.3 x 38.3 mm
- Set dimensions with stand (W x H x D): 519.8 x 380.3 x 144.5 mm
- Box dimensions (W x H x D): 576 x 426 x 108 mm
- Product weight: 3.07 kg
- Product weight (+stand): 3.28 kg
- VESA wall mount compatible: 75 x 75 mm
- Weight incl. Packaging: 4.42 kg

### Accessories

- Included accessories: Remote Control, Batteries for remote control, Power cord, Table top stand, Warranty Leaflet
- Optional accessories: Wallmount (tilt) 22AV3100/10, Set up remote 22AV8573/00

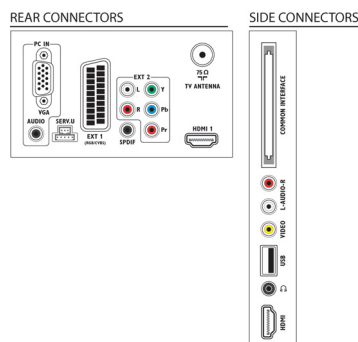

Issue date 2012-09-18  
Owner: Dirk-Jan Mostert  
Version: 0.2.1

12 NC: 8670 000 91919  
EAN: 87 12581 65054 4

Test leaflet, for internal use only!  
© 2012 Koninklijke Philips Electronics N.V.  
All Rights reserved.

Specifications are subject to change without notice.  
Trademarks are the property of Koninklijke Philips Electronics N.V. or their respective owners.

[www.philips.com](http://www.philips.com)